

GLOBAL JOURNAL OF ENGINEERING SCIENCE ANXD RESEARCHES

A REVIEW ON LICENSE PLATE RECOGNITION BASED ANTI SIGNAL DETECTION SYSTEM

Sheetal Mithun Kawade*¹, M.M.Mukhedkar²

Electronics and Telecommunication Department*^{1,2}

Dr.D.Y.Patil COE, Ambi, Talegoan, Dist: Pune*^{1,2}

hotkar_sheetal@yahoo.co.in, moresh.mukhedkar@gmail.com

ABSTRACT

Automatic vehicle identification is an essential stage in intelligent traffic systems. Nowadays vehicles play a very big role in transportation. Also the use of vehicles has been increasing because of population growth and human needs in recent years. Therefore, control of vehicles is becoming a big problem and much more difficult to solve. The aim of this paper is automatic number plate recognition based anti signal detection system using Matlab for effective traffic control. License plate recognition (LPR) is a form of automatic vehicle identification. It is an image processing technology used to identify vehicles by only their license plates. Real time LPR plays a major role in automatic monitoring of traffic rules and maintaining law enforcement on public roads. The extraction of vehicle license plate information from an image or a sequence of images. The extracted information can be used with or without a database in many applications, such as electronic payment systems (toll payment, parking fee payment), and freeway and arterial monitoring systems for traffic surveillance. The ALPR uses either a color, black and white, or infrared camera to take images. ALPR as a real life application has to quickly and successfully process license plates under different environmental conditions, such as indoors, outdoors, day or night time.

Keywords —Automatic license plate recognition (ALPR) system, Literature review, Network formation, System design, Future Scope.

I. INTRODUCTION

License plate recognition systems have received a lot of attention from the research community. With the rapid growth in the number of vehicles, there is a need to improve the existing systems for identification of vehicles. A fully automated system is in demand in order to reduce the dependency on labour. License Plate Recognition is a combination of image processing, character segmentation and recognition technologies used to identify vehicles by their license plates. Since only the license plate information is used for identification, this technology requires no additional hardware to be installed on vehicles. LPR technology is constantly gaining popularity, especially in security and traffic control systems. License Plate Recognition Systems are utilized frequently for access control in buildings and parking areas, law enforcement, stolen car detection, traffic control, automatic toll collection and marketing research [1].

In this paper, the proposed algorithm is based on extraction of plate region, segmentation of plate characters and recognition of characters. Extraction of plate is a difficult task. The difficulty can be due to the following reasons:

- 1) License plates normally, occupy a small portion of the whole image.
- 2) The difference of license plates in formats, styles and colours from country to others.
- 3) In most cases, the detecting is performed without prior knowledge of the license plates location in the image.
- 4) Probability of facing some common drawbacks which could influence the efficiency of the extraction, such as, blurry image, uneven or low illumination, vehicle motion, low resolution of the image, distorted characters, dirty plate, shadows or reflection...etc[2].

The ALPR system that extracts a license plate number from a given image can be composed of four stages. The First stage is to acquire the car image using a camera. The parameters of the camera, such as the type of camera, camera resolution, shutter speed, orientation, and light, have to be considered. The second stage is to extract the license plate from the image based on some features, such as the boundary, the color, or the existence of the characters. The third stage is to segment the license plate and extract the characters by projecting their color information, labelling them, or matching their positions with templates. The final stage is to recognize the extracted characters by template

matching or using classifiers, such as neural networks and fuzzy classifiers. Fig. 1 shows the structure of the ALPR process.

This paper is organized in VII section. Section II explains

Literature review Section III explains ANPR System Section IV explain Network formation Section V explain System design Section VI explain Future Scope, Section VII Conclusion.

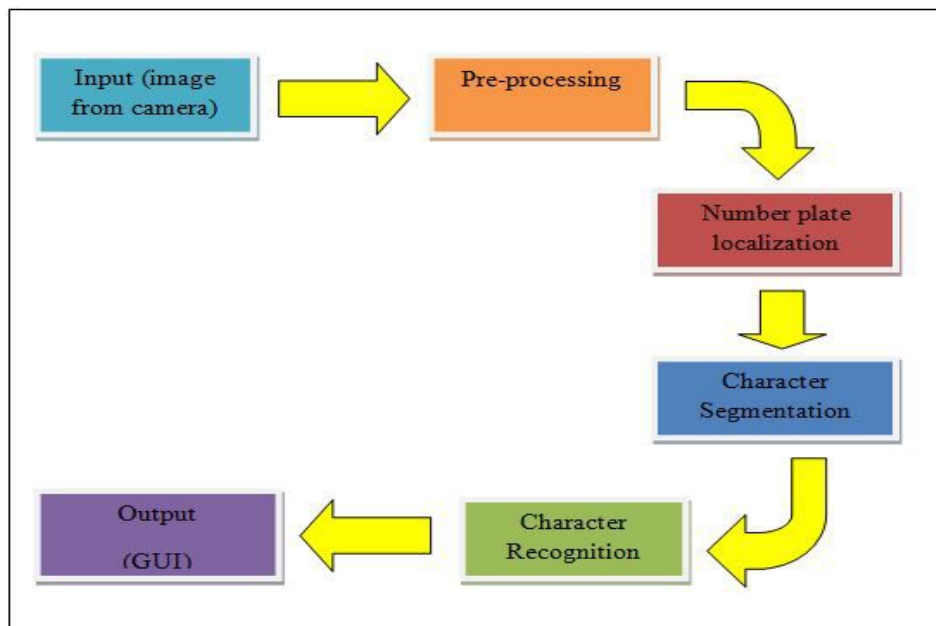

Fig.1 ALPR systems [3].

II. LITERATURE REVIEW

In the literature, many license plate detection algorithms have been proposed. Although license plate detection has been studied for many years, it is still a challenging task to detect license plates from different angles, partial occlusion, or multiple instances. License plate detection investigates an input image to identify some local patches containing license plates. Since a plate can exist anywhere in an image with various sizes, it is infeasible to check every pixel to locate it. Generally, it is preferable to extract some features from images and focus only on those pixels characterized by the license plate. Based on the involved features, traditional license plate detection methods can be classified into three categories: colour-based, edge-based, and texture-based. In what follows, we will review the related work in each category. Colour-based approaches are based on the observation that some countries have specific colours in their license plates. It is intuitive to extract license plates by locating their colours in the images. The collocation of license plate colour and character colour is used to generate an edge image. Then, it checks neighbours of pixels with a value within the license plate colour range to find candidate license plate regions. Edge-based approaches are the most popular, with reliable performance in license plate detection. Generally, as a prior, license plate is characterized by a rectangular shape with a specific aspect ratio, and can be extracted by checking all possible rectangles in the image. kinds of traditional locating methods, some other approaches based on local features have been proposed recently.

III. ANPR SYSTEM

The ANPR system that extracts a license plate number from a given image can be composed of four stages. The first stage is to acquire the car image using a camera. The parameters of the camera, such as the type of camera, camera Resolution, shutter speed, orientation, and light, have to be considered. The second stage is to extract the license plate from the image based on some features, such as the boundary, the color, or the existence of the characters. The third stage is to Segment the license plate and extract the characters by projecting their color information, labelling them, or matching.

A. Image Acquisition

Image Acquisition is the first step in an LPR system and there are a number of ways to acquire images, developed a sensing system, which uses two CCDs (Charge Coupled Devices) and a prism to split an incident ray into two lights with different intensities. The main feature of this sensing system is that it covers wide illumination conditions from twilight to noon under sunshine, and this system is capable of capturing images of fast moving vehicles without blurring.

B. License Plate Extraction

The technique is based on scale shape analysis, which in turn is based on the assumption that, characters have line-type shapes locally and blob-type shapes globally. In the scale shape analysis, Gaussian filters at various scales blur the given image and larger size shapes appear at larger scales. To detect these scales the idea of principal curvature plane is introduced. By means of normalized principal curvatures, characteristic points are extracted from the scale space $x-y-t$. The position (x, y) indicates the position of the figure and the scale t indicates the inherent characteristic size of corresponding figures these entire characteristic points enable the extraction of the figure from the given image that has line-type shapes locally and blob-type shapes globally. The two Neural Networks used are vertical and horizontal filters, which examine small windows of vertical and horizontal cross sections of an image and decide whether each window contains a license plate.

C. License Plate Segmentation Features

This section discusses previous work done for the segmentation of characters. Many different approaches have been proposed in the literature. The basic idea behind region growing is to identify one or more criteria that are characteristic for the desired region. After establishing the criteria, the image is searched for any pixels that fulfil the requirements. Whenever such a pixel is encountered, its neighbours are checked, and if any of the neighbours also match the criteria, both the pixels are considered as belonging to the same region. Used partial differential equations (PDE) based technique; neural network and fuzzy logic were adopted in for segmentation into individual characters.

D Character Recognition

This section presents the methods that were used to classify and then recognize the individual characters. The classification is based on the extracted features. These features are then classified using either the statistical, syntactic or neural approaches their approach identifies the characters based on the number of black pixel rows and columns of the character and comparison of those values to a set of templates or signatures in the database. Template matching involves the use of a database of characters or templates. There is a separate template for each possible input character. Recognition is achieved by comparing the current input character to each of template in order to find the one which matches the best. This approach is based on the detection of holes and concavities in the four directions.

(Up, down, left and right), which permits the classification of characters into different classes. These moments are invariant to scaling, rotation and translation. The obtained moments acts as the features, which are passed to the neural network for the classification or recognition of characters

IV. NETWORK FORMATION

The MLP (Multiple license plates) Network implemented for the purpose of this project is composed of 4 layers, one input, two hidden and one output. The input layer constitutes of 150 neurons which receive pixel binary data from a 10×15 symbol pixel matrix. The size of this matrix was decided taking into consideration the average height and width of character image that can be mapped without introducing any significant pixel noise.

The two hidden layers constitute of 250 neurons each whose number is decided on the basis of optimal results on a trial and error basis. The output layer is composed of 16 neurons corresponding to the 16-bits of Unicode encoding. To initialize the weights a random function was used to assign an initial random number which lies between two preset integers named weight bias.

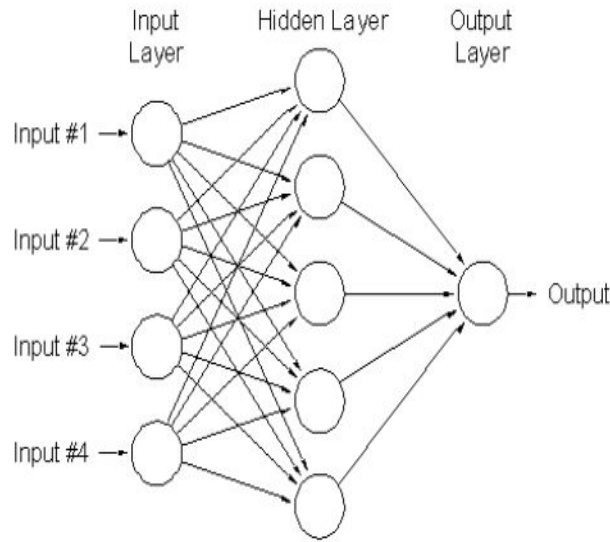

Fig.2 Typical feed forward network with single hidden layer. [4]

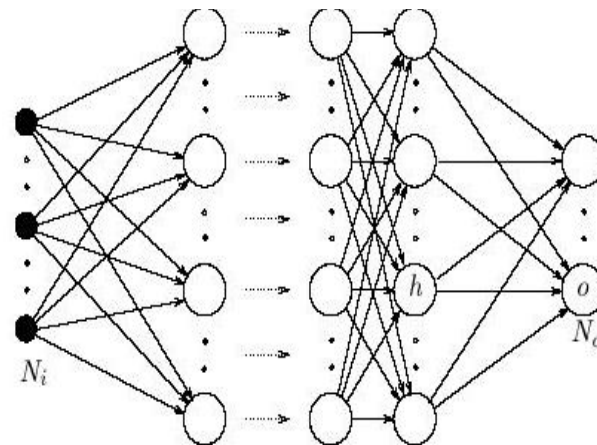

Fig.3 Typical feed forward network with multiple hidden. [4]

V. SYSTEM DESIGN

1) Circuit Diagram Explanation

Here we are placing the IR sensor on the zebra crossing. as soon as any vehicle crosses the stop line, the IR sensor reads the vehicle presence and transmits it to Microcontroller .the Microcontroller then sends the indication to onboard PC which has MATLAB software for automatic Number Plate recognition (ANPR).The MATLAB will then take a snap of the Number plate and using Digital image processing it will extract the vehicle number. Then the PC will send an SMS to RTO unit using “AT” Commands. In RTO we have visual basic based software which will display all the details of the vehicles on PC. After the details are fetched from the database the RTO will send the signal breaking fine indication to the user’s mobile.

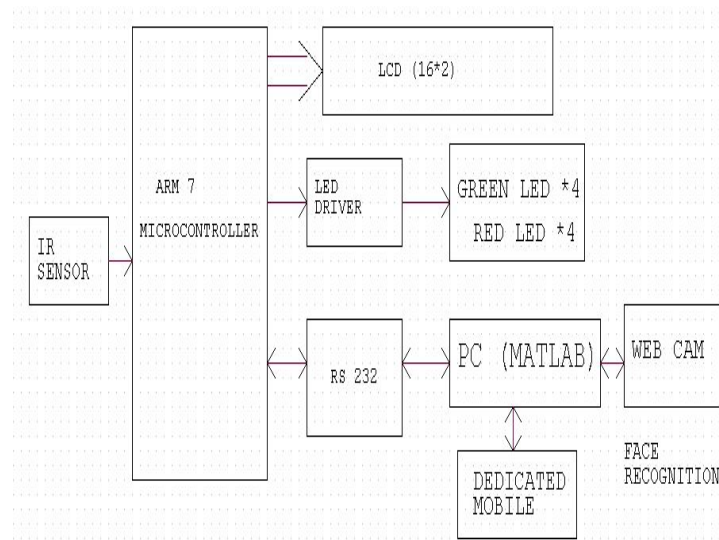

Fig 4.Circuit Diagram

1.1 Infrared Sensor

Proximity detection sensors detect and measure reflected infrared (IR) energy to detect the presence of an object or person. The devices include an integrated LED driver and as in the TMD2671 devices, an integrated LED. The proximity detection devices offer a wide range of performance, with four programmable LED drive currents and IR pulse repetitions. The proximity detection circuitry compensates for ambient light, allowing it to operate in environments ranging from bright sunlight to dark rooms. The wide dynamic range allows operation in short-distance detection applications behind dark glass, such as cell phones. Proximity detection sensors can be used for a mechanical switch replacement or to sense human gesturing.

1.2 Liquid Crystal Display

LCD is used in a project to visualize the output of the application. We have used 16x2 LCD which indicates 16 columns and 2 rows. So, we can write 16 characters in each line. So, total 32 characters we can display on 16x2 LCD. LCD can also be used in a project to check the output of different modules interfaced with the microcontroller. Thus LCD plays a vital role in a project to see the output and to debug the system module wise in case of system failure in order to rectify the problem.

1.3 RS 232

RS 232 is a serial communication cable used in the system. Here, the RS 232 provides the serial communication between the microcontroller and the outside world such as display, PC or Mobile etc. So it is a media used to communicate between microcontroller and the PC. In our project the RS232 serves the function to transfer the edited notice (or data) from PC (MATLAB software) to the microcontroller, for the further operation of the system.

1.4 Web Cam

The image captured by the camera may not be much clear as needed. The number plate can sometimes be muddy due to which the recognition may not be fully possible. Due to extreme climatic conditions such as dense fog, capturing of the number plate would require a very high resolution camera which would increase cost.

1.5 Matrix Laboratory (MATLAB)



MATLAB, which stands for MATrix LABoratory, is a state-of-the-art mathematical software package, which is used extensively in both academia and industry. It is an interactive program for numerical computation and data visualization, which along with its programming capabilities provides a very useful tool for almost all areas of science and engineering. It is a Image Processing Toolbox software that provides a comprehensive set of reference-standard algorithms and graphical tools for image processing, analysis, visualization, and algorithm development. You can restore noisy or degraded images, enhance images for improved intelligibility, extract features, analyze shapes and textures, and register images. Most toolbox functions are written in the MATLAB, giving you the ability to inspect the algorithms, modify the source code, and create your own custom functions.

VI. FUTURE SCOPE

1. The future research of ALPR should concentrate on multistyle plate recognition, video-based ALPR using temporal information, multi plates processing, high definition plate image processing, and ambiguous-character recognition.
2. System that will help in recognizing the number plates automatically and store them into a database. Thus we can say it provides a highly secure environment with lower cost by making the system automatic.
3. For end users it means easy transit through the toll gates and avoiding repeated and hectic security checks at mall parking entrance and society gates.

VII. CONCLUSION

This paper is about building a system that will help in recognizing the number plates automatically and store them into a database. Thus we can say it provides a highly secure environment with lower cost by making the system automatic. Automatic vehicle identification is an essential stage in intelligent traffic systems.

In general, an ALPR system consists of four processing stages. In the image acquisition stage, some points have to be considered when choosing the ALPR system camera, such as the camera resolution and the shutter speed. In the license plate extraction stage, the license plate is extracted based on some features such as the colour, the boundary, or the existence of the characters. In the license plate segmentation stage, the characters are extracted by projecting their colour information, by labelling them, or by matching their positions with template. Finally, the characters are recognized in the character recognition stage by template matching, or by classifiers such as neural networks and fuzzy classifiers. Automatic license plate recognition is quite challenging due to the different license plate formats and the varying environmental conditions. There are numerous ALPR techniques have been proposed in recent years. For end users it means easy transit through the toll gates and avoiding repeated and hectic security checks at mall parking entrance and society gates. In this project we have presented the review of image processing techniques for license plate recognition with various approaches. The experiment has been done in MATLAB to show the basic process of the Image processing especially for license plate.

VIII. REFERENCES

- [1] Lekhana G.C, M.Tech; R.Srikantaswamy, Professor, *International Journal of Advanced Technology & Engineering Research (IJATER) Volume 2, Issue 4, July 2012.*
- [2] Kumar Parasuraman, *An Efficient Method for Indian Vehicle License Plate Extraction and Character Segmentation IEEE International Conference on Computational Intelligence and Computing Research 2010.*
- [3] blocksim.reliasoft.com
- [4] Stuti Asthana, Nireesh Sharma, Rajdeep Singh, *Vehicle number plate recognition using multiplelayer back propagation neural networks International Journal of Computer Technology and Electronics Engineering (IJCTEE) Volume 1, Issue 1*
- [5] Liannwen JIN, JianZhao QI, "Car plate number characters recognition using Gabor Orientation features and neural networks.", *IEEE International Conference On Neural Networks and Signal Processing*, pp. 1628-1631, 2003

- [6] Chirag N. Paunwala, Suprava Patnaik, “A Novel Multiple License Plate Extraction Technique for Complex Background in Indian Traffic Conditions”, In *Proceedings of International Journal of Image Processing*, vol.4, issue2, 2007.
- [7] Kuo-Ming Hung, Hsiang-Lin Chuang, Ching-Tang Hsieh, “License Plate Detection Based on Expanded Haar Wavelet transform”, *IEEE Fourth International Conference on Fuzzy Systems and Knowledge Discovery*, pp. 415-419.
- [8] Chetan Sharma¹ and Amandeep Kaur², “ INDIAN VEHICLE LICENSE PLATE EXTRACTION AND SEGMENTATION”, *International Journal of Computer Science and Communication*, Vol. 2, No. 2, pp. 593-599, July-December 2011
- [9] G. Liu, Z. Ma, Z. Du, and C. Wen, “The calculation method of road Travel time based on license plate recognition technology,” in *Proc. Adv. Inform. Tech. Educ. Commun. Comput. Inform. Sci.*, vol. 201. 2011, pp
- [10] E. Tzafestas, A. Nikolaidou and S. Tzafestas, “Performance Evaluation and Dynamic Node Generation Criteria for Principal Component Analysis, Neural Network”, *Mathematics and Computer in Simulation*, Vol. 51, pp.145-156, 300, 2004
- [11] Roy, A.; Ghoshal, D.P.” Number Plate Recognition for use in different countries using an improved segmentation” *IEEE Conference Publications* 2011.
- [12] Humayun Karim Sulehria, Ye Zhang, Danish Irfan, Atif Karim Sulehria,” *Vehicle Number Plate Recognition Using Mathematical Morphology and Neural Networks*”, *WSEAS TRANSACTIONS on COMPUTERS*, Volume 7,ISSN: 1109- 2750, Issue 6, June 2008
- [13] Wengang Zhou, Houqiang Li, Yijuan Lu, Member, IEEE, and Qi Tian, Senior Member, IEEE, “Principal Visual Word Discovery for Automatic License Plate Detection”, *IEEE transaction on image processing* ,vol21, NO. 9, September 2012
- [14] Shyang-Lih Chang, Li-Shien Chen, Yun-Chung Chung, and Sei-Wan Chen , “Automatic License Plate Recognition, *IEEE transactions on intelligent transportation systems*, Vol. 5, March 2004
- [15] Shishir Kumar, Shashank Agarwal & Kumar Saurabh, “License plate recognition system for Indian vehicles”, *IEEE Eighth International Conference on Intelligent transportation System*, Vol.1, pp.311-325, 2008.
- [16] Zhen-Xue Chen, Cheng-Yun Liu, Fa-Liang Chang, and Guo-You Wang, “ Automatic License-Plate Location and Recognition Based on Feature Saliency”, *IEEE Transaction on vehicle technology*, VOL. 58, NO. 7, september 2009
- [17] 6th IEEE International Workshop on Cellular Neural Networks and their Applications, IEEE.2000pp.63-8. Piscataway, NJ, USA
- [18] HUANG Wei, LU Xiaobo & LING Xiaojing, “Wavelet packet based feature extraction and recognition of license plate characters”, *IEEE Chinese Science Bulletin* Vol.50, pp.97-100, 2005